

UDK: 622.244

Originalni naučni rad
Original scientific paper

INSIDE OVERPRESSURE UTILIZATION FOR A STABILITY INCREASING AT THE THIN-WALLED ROTATIONAL SYMMETRICAL SHELL STRAINED BY AXIAL FORCE

Stanislav Kotšmíd*, Marián Minárik

*Technical University in Zvolen, Faculty of Environmental and Manufacturing
Technology, Department of Mechanics and Mechanical Engineering,
Zvolen, Slovak Republic*

Abstract: The members, strained by axial force, are used in the different areas of human activities. If members have a big slenderness, it can to origin a problem with losing of their stability. One of the possibilities, how can be partially eliminated this deficiency with not extending its parameters and of course its mass, is adding of force effects, which will be operate against to force effects making of stability losing. The article deals with theoretical possibility of stability increasing by adding of inside overpressure. It describes allocation and interaction of effected stresses according to the appropriate formulas and solves concrete sample. Last but not least, it shows graphical layout of effect stresses and satisfaction of stability condition with regard to different values of inside overpressure and geometrical parameters of members. The article brings a possible way of members stability increasing and in case of experimental verification we can predict favourable future of this.

Key words: *buckling, stability, shell, overpressure*

INTRODUCTION

The straining of members by axial force is often occurred in the different industrial machines in agriculture, forestry, architecture and engineering. In the practice, the engineers effort to create members with a small mass and a high carrying capacity, so it directs to making a slender struts, which can succumb losing of the shape stability under

* Corresponding author. E-mail: stanislav.kotsmid@gmail.com

axial force loading. Losing of stability is a status of strut, where are created conditions for solid transition from stable to unstable position, when this transition is characterised by changing of solid shape.

While the value of force, which causes the pressure stress in the strut, is not higher than critical value, which is dependent on the strut connecting, the strut is straight and it is strained on pressure only. If the critical value is exceeded, deformation of the strut increases until its destruction. This critical value is called critical buckling force, which characterises losing of stability.

By this value can be solved critical stress in struts. In depending on connecting condition, geometrical parameters and strut material, this stress can be much less than the yield value, so material is not utilized in sufficient degree. Here is created question, how can be increased utilization of strut, if we do not want to extend its geometrical parameters and its mass of course. We assume, one of the way is adding of the force effect, which will be operate against to force effect making pressure.

MATERIAL AND METHODS

There can be determined critical buckling force for prismatic, centric pressured strut by procedure, which was elaborated by Leonhard Euler. If we suppose homogeny material of the strut and unlimited validity of the Hook law, the strut is stable and has straight shape at small axial force.

If this axial force achieves critical value, the strut is in indifferent balance and it stays in new deformed shape with bended axis (Fig. 1) [1, 3, 6, 7].

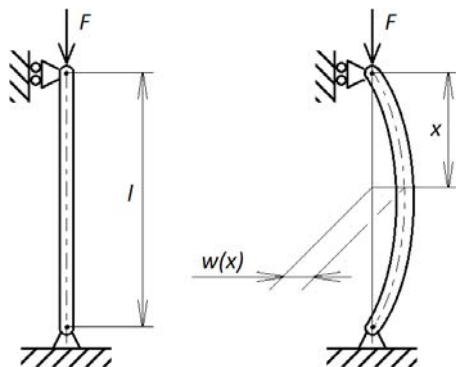

Figure 1. Deformation of the strut by axial force F

The computing of critical buckling force can be deduced by procedure, which is described in literature [6]. Final formula for computing of this force is:

$$F_{krit} = \frac{n^2 \cdot \pi^2 \cdot E \cdot J_{min}}{(\beta \cdot l)^2} \quad (1)$$

Where:

- n [-] - constant, which determines shape of bended line,
- E [Pa] - Young modulus of elasticity,

J_{min}	[m ⁴]	- minimum quadratic moment of strut cross section,
β	[-]	- buckling coefficient,
l	[m]	- length of strut.

The critical stress in strut is computed as:

$$\sigma_{krit} = \frac{F_{krit}}{A} \quad (2)$$

Where:

A	[m ²]	- cross section area.
-----	-------------------	-----------------------

Let investigate, what will happen, if strut, constructed as shell, is strained by inside overpressure except axial force (Fig. 2).

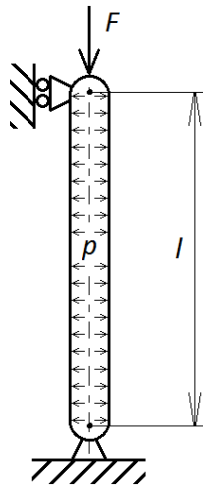

Figure 2. The shell strained by axial force and inside overpressure

At the shells (ratio of the inside diameter and the wall thickness is smaller than 0.1) as members of the planar character, can be used a membrane theory for computing in some cases. This theory ignores effect of bending and torsion moments, and feed and contact force, so it makes solution of problem easier [1, 4, 5].

For using of this theory must be met next conditions. Geometrical parameters of the shell (thickness, radius of curvature, centre of curvature) must be changed continuously. Alone forces, which strain of the shell, must operate in contact plane to middle surface. Straining of the shell does not have to be changed suddenly. Connecting of the shell must be statically determinate. If any from these rules is not right, it can cause bending and torsion moments there, what makes solution of task harder [1, 4, 6].

In the shell can be created three planes through some point P ; the contact plane to middle surface, the meridian plane in which is situated axis of symmetry and plane, which is perpendicular on previous two. Let extract infinity small element near to point P (Fig. 3) [2, 3, 6].

In the places of element operate only normal stresses σ_m and σ_t . If inside overpressure p operates there, condition of static at the element balance in direction of the normal n to middle surface has form:

$$p \cdot ds_m \cdot ds_t - 2 \cdot \sigma_m \cdot h \cdot ds_t \cdot \sin \frac{d\vartheta_m}{2} - 2 \cdot \sigma_t \cdot h \cdot ds_m \cdot \sin \frac{d\vartheta_t}{2} = 0 \quad (3)$$

Where:

p	[Pa]	- inside overpressure in the shell,
h	[m]	- thickness of the wall,
σ_m	[Pa]	- meridian stress,
σ_t	[Pa]	- tangent stress,
ds_m	[m]	- element height,
ds_t	[m]	- element width,
d_m	[°]	- angle of element curvature in meridian direction,
d_t	[°]	- angle of element curvature in tangent direction,
ρ_m	[m]	- radius of element curvature in meridian direction,
ρ_t	[m]	- radius of element curvature in tangent direction.

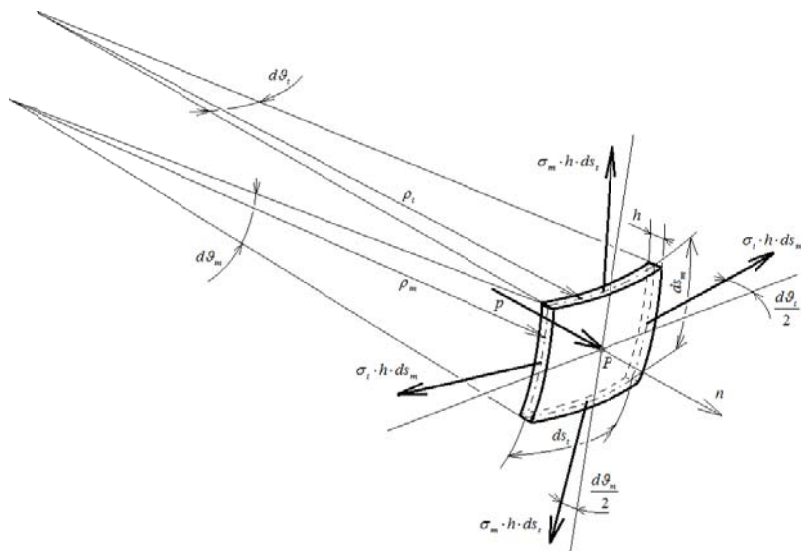

Figure 3. Element of the shell

After putting and removing of the special part in formula we get Laplace formula:

$$\frac{\sigma_m}{\rho_m} + \frac{\sigma_t}{\rho_t} = \frac{p}{h} \quad (4)$$

This formula gives relation among tangent stress σ_t , meridian stress σ_m , inside overpressure p and geometrical parameters h , ρ_m and ρ_t .

Next needed formula for solution is condition of equilibrium for part of the shell, which is cutting by the plane, perpendicular on the axis of rotation.

$$\sum F_{ix} = 0 \quad p \cdot \pi \cdot r^2 - 2 \cdot \sigma_m \cdot \pi \cdot r \cdot h = 0 \tag{5}$$

Where:

r [m] - shell radius.

After putting $\rho_t = r$ and $\rho_m = \infty$ we get for σ_m and σ_t formulas:

$$\sigma_t = \frac{p \cdot r}{h} \tag{6}$$

$$\sigma_m = \frac{p \cdot r}{2 \cdot h} \tag{7}$$

This theory predicts operating of stresses in tangent and meridian direction, what is stress operated in the shell axial direction. It is tensile stress and wants to stretch the shell in axial direction. As we have written, axial force causes compression stress. Both stresses operate in the same direction and in the same plane so they can be algebraic summed up and from this sum and tangent stress can be made up reduce stress according to one of the strength theories. There can be different results of this sum. If there will be zero compression stress, only meridian stress will be operate in axial direction. If there will be compression stress equal to meridian stress, no stress will be operate in axial direction. If there will be compression stress higher than meridian stress, pressure will be operate in axial direction and after exceeding of the critical value, losing of stability come soon. So stability condition can have this form:

$$\sigma_m - \sigma_{tl} + \sigma_{krit} > 0 \tag{8}$$

Where:

σ_{tl} [Pa] - compression stress caused by axial force F .

For computing of reduce stress can be used theory HMM. Formula has next form

$$\sigma_{red}^{HMH} = \sqrt{(\sigma_m - \sigma_d)^2 + \sigma_t^2 - (|\sigma_m - \sigma_d|) \cdot \sigma_t} \tag{9}$$

On the basic of previous ideas, let solve next task, where will be investigated the shape stability of pipe strained by axial force. Pipe will be strained by force $F = 5\,000\text{ N}$, on the both ends will be connected by a joint and will have outside diameter $D = 17\text{ mm}$, wall thickness $h = 1\text{ mm}$ and length $l = 1\text{ m}$. Material of pipe is chosen with yield value $R_e = 180\text{ MPa}$ and safety coefficient $k = 2$.

We can use Euler formula (1) and formulas for computing of critical buckling and compression stress.

$$F_{krit} = \frac{1^2 \cdot \pi^2 \cdot 2,1 \cdot 10^{11} \cdot \frac{\pi \cdot (0,017^4 - 0,015^4)}{64}}{(1 \cdot 1)^2} = 3346,82\text{ N}$$

$$\sigma_{krit} = \frac{3346,82}{\frac{\pi \cdot (0,017^2 - 0,015^2)}{4}} = 66,58\text{ MPa}$$

$$\sigma_{ii} = \frac{5000}{\frac{\pi \cdot (0,017^2 - 0,015^2)}{4}} = 99,47 \text{ MPa}$$

Next we add the inside overpressure in pipe $p = 10 \text{ MPa}$. Then tangent and meridian stresses have values:

$$\sigma_t = \frac{10 \cdot 8}{1} = 80 \text{ MPa}$$

$$\sigma_m = \frac{10 \cdot 8}{2 \cdot 1} = 40 \text{ MPa}$$

According to formula (8) for stability condition we get:

$$40 - 99,47 + 66,58 = 7,11 > 0$$

what means, there is no losing of stability. Reduce stress has value:

$$\sigma_{red}^{HMH} = \sqrt{(40 - 99,47)^2 + 80^2 - ((40 - 99,47) \cdot 80)} = 72 \text{ MPa}$$

RESULTS AND DISCUSSION

As we can see from computed values in previous part, computed F_{krit} is smaller than axial force F . According to this, the pipe can lose its stability. Compression stress is higher than critical buckling stress too. Pipe does not meet stability condition.

Table 1. Dependence of stresses and stability condition of pipe according to the inside overpressure value

$p \text{ (MPa)}$	$\sigma_m \text{ (MPa)}$	$\sigma_t \text{ (MPa)}$	$\sigma_{ii} \text{ (MPa)}$	$\sigma_{red} \text{ (MPa)}$	$\sigma_m - \sigma_{ii} + \sigma_{krit} \text{ (MPa)}$
0	0	0	99,47	99,47	-32,89
1	4	8		91,73	-28,89
2	8	16		84,61	-24,89
3	12	24		78,28	-20,89
4	16	32		72,94	-16,89
5	20	40		68,83	-12,89
6	24	48		66,16	-8,89
7	28	56		65,13	-4,89
8	32	64		65,80	-0,89
9	36	72		68,14	3,11
10	40	80		71,97	7,11
11	44	88		77,07	11,11
12	48	96		83,21	15,11
13	52	104	90,18	19,11	

With straining of pipe by inside overpressure was created meridian stress in the wall, which operates against to compression stress. The pipe after application meets stability condition and reduce stress is smaller than permissible stress too. Table 1 shows

how these stresses and stability condition are changed according to value of inside overpressure.

From this table we can see that under value 8 MPa of inside overpressure, last column is negative. It means inside overpressure is too small for compensation of the pressure caused by axial force F . Only when value is equals 8.22 MPa, it can be met stability condition. When there are higher values of inside overpressure, stability condition is met. There is meridian stress still smaller than compression stress caused by axial force F .

From the table we can see that values of reduce stress reaches permissible stress before value 13 MPa of inside overpressure, but meridian stress is still smaller than compression stress. It is caused by increasing of tangent stress. It brings idea that inside overpressure cannot be increased without control.

Fig. 4 shows activity of stresses in pipe and fact, that we get the smallest reduce stress, when inside overpressure is on the limit of stability.

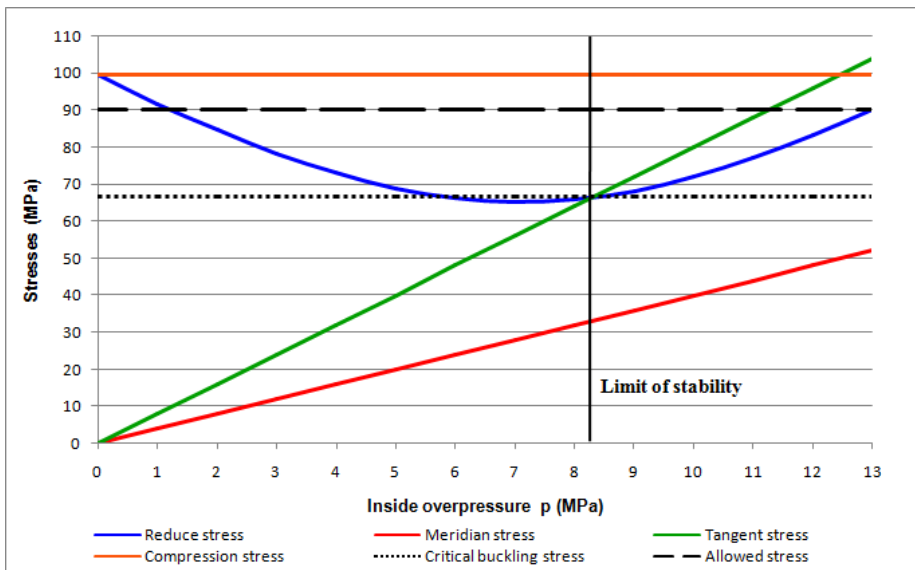

Figure 4. Dependence of stresses according to the inside overpressure changing

Fig. 5 shows, how reduce stress in the pipe is changed according to inside overpressure and outside diameter. In this case can be said, with decreasing of inside overpressure is needed increasing of geometrical parameters for decreasing of reduce stress, and inside out.

Fig. 6 shows to meet stability condition according to pipe outside diameter and inside overpressure changing. We can see, at value of outside diameter 15 mm is all interval of stability values for inside overpressure 0 – 15 MPa in negative values. It means, any shown value of inside overpressure do not compensate compressive stress for no losing of stability. On the other hand, in value of outside diameter 20 mm is all values in positive interval, so inside overpressure is not needed there, but it can helps to

decreasing of reduce stress. From this we can bring idea, with increasing of pipe outside diameter is needed smaller inside overpressure to stability safety.

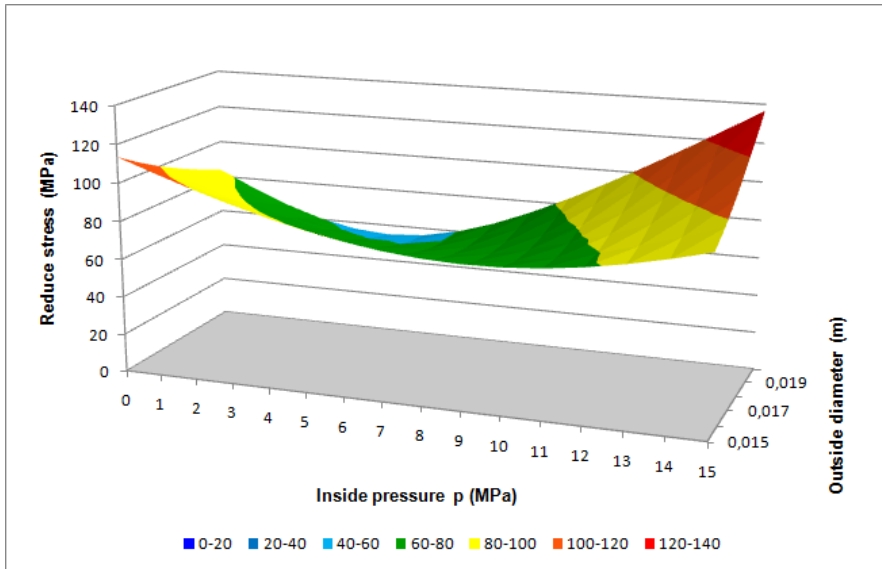

Figure 5. Dependence of reduce tension according to pipe diameter and inside overpressure changing

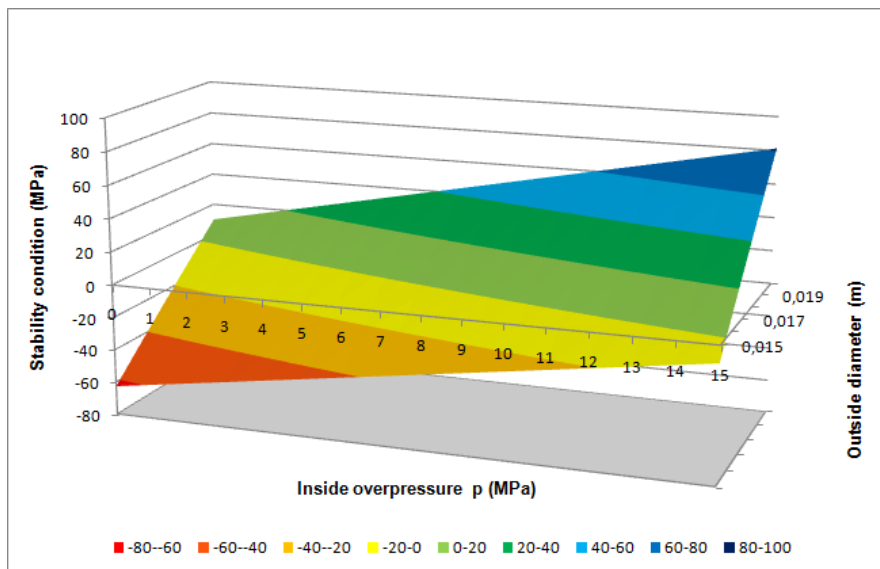

Figure 6. Dependence of meet condition according to pipe outside diameter and inside overpressure changing

CONCLUSIONS

In the present, when the utilization of materials is increased, research and development is oriented on new materials like the composites. Yield value of materials and of course their utilization can be increased by suitable structure and constitution of materials. The next way is to better know the character and the straining of forces and create the way, how these force effects can be partially eliminated by their allocation, or adding of force effects which will operate in the opposite direction.

In the article is shown elimination of origin force effects by adding of another force effects operated in opposite direction. Computation shows, that this way can have invocation in future. Except of experimental verification, there will have to be solved another aspects for implementation of this way to the practise.

One of the aspects is the shape of heads and technology of their connecting. In a pressure vessels is often used a plate circular head, which is welded to the shell. This simple solution causes existence of superior stress, so there might be create relieve by means a race around all circuit and thickness of the head might be higher than thickness of the shell.

The next aspect is an assurance of the clear membrane state in inside forces, what means the assurance of necessary deformation and static equilibrium only through membrane forces. In the practise it means to solve suitable location. At last but not least will be necessary to see on safety at escape of inside overpressure from the pipe.

We suppose that after solving previous aspects, this way of material efficiency increasing can have favourable future.

BIBLIOGRAPHY

- [1] Bischoff, M., Bletzinger, K. U., Wall, W. A., Ramm, E. 2004. *Models and finite elements for thin-walled structures* In: *Encyclopedia of computational mechanics*. USA: John Wiley & Sons, Inc.
- [2] Bodnár, F., Minárik, M. 2009. *Pružnosť a pevnosť II*. Zvolen: Technická univerzita vo Zvolene.
- [3] Hájek, E., Reif, P., Valenta, F. 1988. *Pružnosť a pevnosť I*. Praha: SNTL.
- [4] Riley, W. F., Strurges, L. D. 1993. *Engineering mechanics – Statics I*. USA: John Wiley & Sons, Inc.
- [5] Schafer, B. 2002. Local, distortional, and Euler buckling of thin-walled columns. *Journal of structural engineering*. Volume 128. Issue 3. 10 pages.
- [6] Trebuňa, F., Jurica, V., Šimčák, F. 2000. *Pružnosť a pevnosť II*. Košice: Vienaľa.
- [7] Trebuňa, F., Šimčák, F. 1999. *Tenkostenné nosné prvky a konštrukcie*. Košice: Vienaľa.

UPOTREBA UNUTRAŠNJEG NADPRITISKA ZA POVEĆANJE STABILNOSTI TANKOG ZIDA ROTACIONE SIMETRIČNE OPLATE OPTEREĆENE AKSIJALNOM SILOM

Stanislav Kotšmíd, Marián Minárik

*Tehnički univerzitet u Zvolenu, Fakultet za životnu sredinu proizvodnu tehnologiju,
Institut za mehaniku i mašinstvo, Zvolen, Republika Slovačka*

Sažetak: Elementi, opterećeni aksijalnom silom, se koriste u raznim oblastima. Ako su savitljivi, mogu izgubiti svoju stabilnost. Jedna od mogućnosti za delimično otklanjanje ovog nedostatka, bez ojačavanja i povećanja mase, je dodavanje sile koja će delovati suprotno tako da uravnoteži opterećeni element. Ovaj rad obrađuje teorijsku mogućnost povećanja stabilnosti dodavanjem unutrašnjeg nadpritiska. Opisan je položaj i interakcija opterećenja odgovarajućim jednačinama i dobijeno rešenje konkretnog problema. Pokazan je i grafički prikaz dobijenog efekta i zadovoljenje uslova stabilnosti u odnosu na različite vrednosti unutrašnjeg nadpritiska i geometrijskih parametara elemenata. U radu je dat i poseban način povećanja stabilnosti elemenata i eksperimentalne verifikacije daljih postupaka.

Ključne reči: *izvijanje, stabilnost, oplata, nadpritisak*

Prijavljen: 15.08.2013.
Submitted:
Ispravljen:
Revised:
Prihvaćen: 12.02.2014.
Accepted: