

UDK: 621.47:620.91

*Originalni naučni rad  
Original scientific paper*

## **ANALYTICAL ASPECTS FOR CONSTRUCTION OF SOLAR COLLECTOR WITH REFLECTORS**

**Liene Kancevica<sup>1\*</sup>, Aivars Aboltins<sup>2</sup>**

<sup>1</sup> *Latvia University of Agriculture, Faculty of Engineering, Institute of Agricultural Energetics, Jelgava, Latvia*

<sup>2</sup> *Latvia University of Agriculture, Faculty of Engineering, Institute of Agriculture Machinery, Jelgava, Latvia*

**Abstract:** The research of a solar collector with reflectors was performed. Considering this type of the solar collector it is important to evaluate the geometric parameters and position of irradiated solar collector. The article deals with analyzes of implication of the mirror distance and the rotation angle to the collector efficiency. The article presents the foundation of the right and left side mirror rotation angle to the collector surface. The angle is dependent on the mirror size, and the placement distance from the collector is shown.

**Key words:** *solar radiation, solar collector, reflectors, angle*

### **INTRODUCTION**

The greatest advantage of solar energy comparing with other forms of energy is that it is clean and can be supplied without environmental pollution. Solar energy is used to heat and cool buildings (both actively and passively), dry products, heat water for domestic and industry use, heat swimming pools, generate electricity for chemistry applications and many other operations [1].

The application of solar energy is completely dependent on solar radiation, a low-grade and fluctuating energy source. In general, solar water heaters are flat-plate collectors. An intrinsic difficulty in using solar energy is caused by the wide variation in the solar radiation intensity. To obtain the additional radiation the reflectors (mirrors) are used. Particularly wide mirrors are used for the spherical collectors [2], but those have been studied less for the flat plate solar collectors. Practical researches on the usage of additional radiation were performed at the Research Institute of Agricultural Machinery

---

\* Corresponding author: Liene Kancevica, J.Cakstes bulv. 5, Jelgava, Latvia, LV-3001.  
E-mail: Liene.Kancevica@llu.lv

[3]. The research experiment has shown the increase of the efficiency of a collector, irradiating the collector plane with the addition of solar radiation by the gain from the additional reflectors.

The aim of the research was to find the influence of the mirror distance and rotation angle to the collector working efficiency and the angles dependence on the mirror size and the distance to the placement of the solar collector.

## MATERIAL AND METHODS

Flat-plate solar collectors receive solar energy directly from the sun, the typical flat-plate solar collector receives solar radiation through the transparent cover. In order to increase the received amount of energy the reflecting mirrors can be used, in addition to irradiate the collector surface, thereby increasing the common solar irradiance.

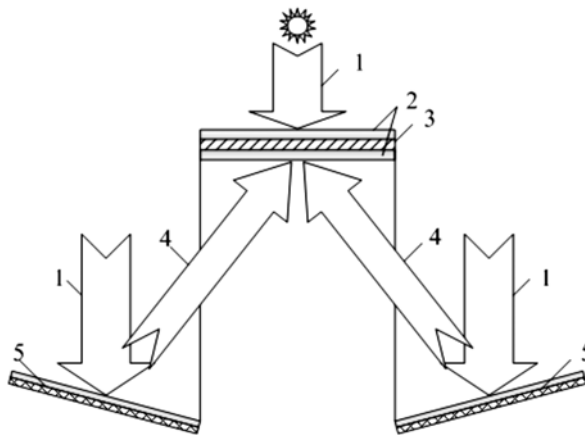

Figure 1. Principal scheme of solar collector with reflectors: 1 – falling sun rays, 2 – collector cover (glass), 3 – absorber, 4 – reflection sun rays, 5 – reflectors

For the experimental research was constructed the solar collector with reflectors was constructed [4]. The absorber (3) positioned in the middle of the collector, and the collector cover (glass) (2) placed on either side of the collector (Fig. 1). The solar collector with reflectors (5) has been merged into one single framework, and their location influenced the angle of incidence of solar radiation.

The absorber plate receives direct solar radiation (1) and reflective (or additional) radiation (4) from the reflectors.

## RESULTS AND DISCUSSION

Firstly, we determined the rotation angles of the mirror for solar incident rays, reflecting from the mirror, projected to the absorber of the solar collector. For this reason the left mirror rotation angle detection scheme was created (Fig. 2).

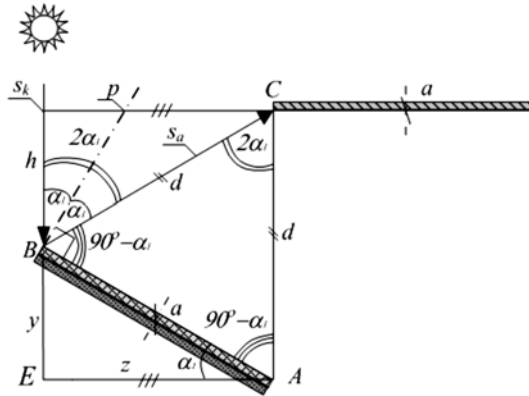

Figure 2. Detection scheme for left mirror rotation angle  $\alpha_1$

Suppose that the length of the absorber and mirror are equal –  $a$ . To comply the rules, provided that after mirror rotation the right side point  $A$  is located directly in front of the absorber point  $C$ . Consider that the mirror must be positioned so that to the mirror point  $B$  the falling solar ray  $s_k$  is reflected to the absorber point  $C$ . The distance from the absorber point  $C$  to the mirror point  $A$  is denoted by  $d$ . The light reflection angle equals the angle of incidence of light. So, changing the mirror rotation by  $\alpha_1$ , the incident ray  $s_k$  on the point  $B$  made an angle  $\alpha_1$  with mirror perpendicular  $p$ , and the reflected ray  $s_a$  with perpendicular  $p$  forms an angle  $\alpha_1$ . Thus, the angle between the incident and reflected rays will be equal to  $2\alpha_1$ .

From  $\Delta ABC$  followed that  $AC = BC = d$ . Using the cosine theorem  $a^2 = 2d^2 - 2d^2 \cdot \cos 2\alpha_1$  we find the rotation angle  $\alpha_1$  dependence on the mirror length  $a$ , and the placement distance  $d$ :

$$\sin \alpha_1 = \frac{a}{2d^2} \quad (1)$$

or

$$\alpha_1 = \arcsin \frac{a}{2d} \quad (2)$$

Consider a right-angled triangle  $ABE$  (Fig. 2), where the side  $AE$  is the projection of the mirror to the horizontal axis -  $z$ . From  $\Delta ABE$  follows that:  $z = a \cdot \cos \alpha_1$ , and the distance from the left edge of the mirror to the projection  $y = z \cdot \tg \alpha_1$ . While the size of  $h$  can be expressed:

$$h = d - a \cdot \sin \alpha_1 \quad (3)$$

Similarly the position of the right side mirror can be obtained. Assume that the reflected ray from left point  $G$  of the right mirror falls on the left side of the absorber point  $C$  (Fig. 3).

Describing a rotation angle of the mirror with  $\alpha_2$ , the angle between the incident ray  $s_k$  and reflected ray  $s_a$  will be equal to  $2\alpha_2$ .  $\Delta CGD$ , with the already known values  $a$  and  $d$ , determined the angle  $\alpha_2$ :

$$\text{tg } 2\alpha_2 = \frac{a}{d} \tag{4}$$

or

$$\alpha_2 = \frac{1}{2} \text{arctg } \frac{a}{d} \tag{5}$$

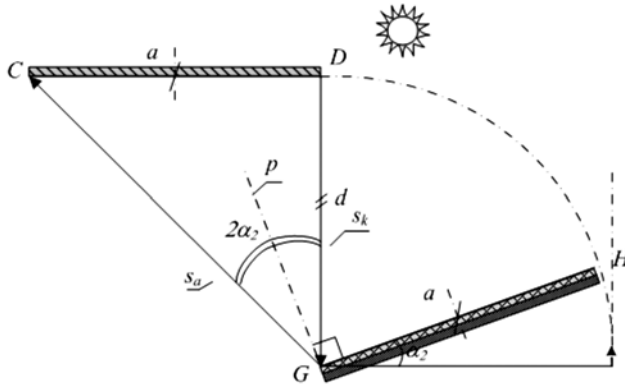

Figure 3. Detection scheme for right mirror rotation angle  $\alpha_2$

At the constant position of the collector the reflective angle from the point  $H$  will be reflected outside of the absorber plane. It will be reflected on the right point  $D$  of the absorber when the Earth turned after some moment of time.

Table 1. Estimates of mirror rotation angle  $\alpha_1$

$\frac{a}{d}$	0.1	0.2	0.3	0.4	0.5	0.6	0.7	0.8	0.9	1
0.1	<b>30</b>	87	-	-	-	-	-	-	-	-
0.2	14.3	<b>30</b>	48.6	87	-	-	-	-	-	-
0.3	9.6	19.5	<b>30</b>	41.8	56.4	87	-	-	-	-
0.4	7.2	14.5	22	<b>30</b>	38.7	48.6	61	87	-	-
0.5	5.7	11.5	17.5	23.6	<b>30</b>	36.9	44.4	53.1	64.1	87
0.6	4.8	9.6	14.5	19.5	24.6	<b>30</b>	35.7	41.8	48.6	56.4
0.7	4.1	8.2	12.4	16.6	20.9	25.4	<b>30</b>	34.9	40	45.6
0.8	3.6	7.2	10.8	14.5	18.2	22	25.9	<b>30</b>	34.2	38.7
0.9	3.2	6.4	9.6	12.8	16.1	19.5	22.9	26.3	<b>30</b>	33.8
1	2.9	5.7	8.6	11.5	14.5	17.5	20.5	23.6	26.7	<b>30</b>

As a result of finding correlations (2) and (5), we see that the right and left side mirror placement angle depends on the size of the collector absorber length  $a$  and

placement distance  $d$ . For produced practical devices Table 1 and Table 2 can be used, which shows the minimum allowable right side (Tab. 2) and maximum allowable left side (Tab. 1) mirror angles.

Table 2. Estimates of mirror rotation angle  $\alpha_2$

$\frac{a}{d}$	0.1	0.2	0.3	0.4	0.5	0.6	0.7	0.8	0.9	1
0.1	<b>22.5</b>	31.7	35.8	38	39.4	40.3	40.9	41.4	41.8	42.1
0.2	13.3	<b>22.5</b>	28.2	31.7	34.1	35.8	37	38	38.7	39.4
0.3	9.2	16.9	<b>22.5</b>	26.6	29.5	31.7	33.4	34.7	35.8	36.7
0.4	7	13.3	18.4	<b>22.5</b>	25.7	28.2	30.1	31.7	33	34.1
0.5	5.7	10.9	15.5	19.3	<b>22.5</b>	25.1	27.2	29	30.5	31.7
0.6	4.7	9.2	13.3	16.9	19.9	<b>22.5</b>	24.7	26.6	28.2	29.5
0.7	4.1	8	11.6	14.9	17.8	20.3	<b>22.5</b>	24.4	26.1	29.5
0.8	3.6	7	10.3	13.3	16	18.4	20.6	<b>22.5</b>	24.2	25.7
0.9	3.2	6.3	9.2	12	14.5	16.9	18.9	20.8	<b>22.5</b>	24
1	2.9	5.7	8.4	10.9	13.3	15.5	17.5	19.3	21	<b>22.5</b>

$a$  and  $d$  are a relative absorber and mirror distance values. If both are the same (diagonal in tables) the rotation angle of the right mirror  $\alpha_2 = 22.5^\circ$  and of the left mirror  $\alpha_1 = 30^\circ$ . As we can see, the right and left side mirror rotation angle is not the same. This can be explained by the fact that  $\alpha_1$  – maximum the possible angle of rotation and  $\alpha_2$  – minimum possible angle of rotation.

The corresponding mirror angles dependence is shown on Fig. 4.

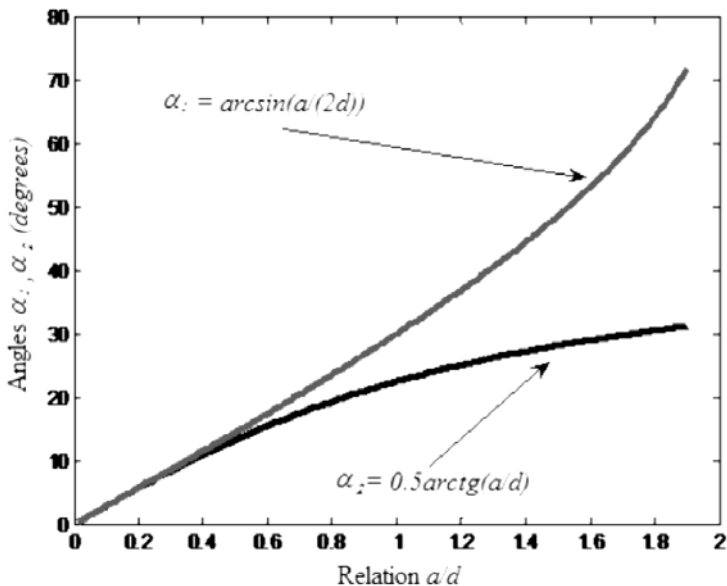

Figure 4. Dependence of right side and left side mirror angles

As it can be seen at low  $a$  and  $d$  relations the rotation angles differ little from each other. Starting with the ratio of 0.6, this difference begins to increase significantly (Fig. 4), where the ratio 1.7 the left angle (maximum angle) becomes three times higher for the right side angle (the minimum allowable angle). Using these angles it is possible to determine the time interval, the collector absorber is fully irradiated from the mirror collector while in a stationary position.

## CONCLUSIONS

Assuming that the mirror and absorber are equal, min and max mirror angle placement is found.

Using the resulting relationships the placement an appropriate distance from the mirror at a certain angle can be detected.

Continuing research, the obtained values will provide an opportunity to determine turning the mechanism of the solar collector with reflectors.

## BIBLIOGRAPHY

- [1] Twidell, J.W., Weir, A.D., 1990. *Renewable energy resources*. London: E.& F.N. Spon, pp. 392.
- [2] Харченко, Н.В., 1991. *Индивидуальные солнечные установки*. Москва: Энергоиздат, 208 стр.
- [3] Ziemelis, I., Putans, H., Kancevica, L., 2010. Investigation of Solar Collector Irradiated from Both Sides. *Proceedings of International conference "Scientific achievements for wellbeing and development of society"*, ISSN 1406-894X. Tartu, Estonia, pp. 280-286.
- [4] Kancevica, L., Putans, H., Ziemelis, I., 2006. Mirror-collector for solar water heating. *Proceedings of International conference "Engineering for rural development"*, ISSN 1691-3043. Latvia: Jelgava, pp. 181-185.

## ANALITIČKI ASPEKTI KONSTRUISANJA SOLARNOG KOLEKTORA SA REFLEKTORIMA

**Liene Kancevica<sup>1</sup>, Aivars Aboltins<sup>2</sup>**

<sup>1</sup> *Letonski Poljoprivredni univerzitet, Fakultet za inženjering, Institut za poljoprivrednu energetiku, Jelgava, Letonija*

<sup>2</sup> *Letonski Poljoprivredni univerzitet, Fakultet za inženjering, Institut za poljoprivredne mašine, Jelgava, Letonija*

**Sažetak:** U radu su prikazani rezultati ispitivanja solarnog kolektora sa reflektorima. Imajući u vidu ovaj tip solarnog kolektora, važno je proceniti geometrijske parametre i položaj solarnog kolektora izložеног zračenju. U radu su prikazane analize uticaja udaljenosti ogledala i ugla zakretanja na efikasnost kolektora. Rad predstavlja osnovu

ugla rotacije desnog i levog bočnog ogledala u odnosu na površinu kolektora. Ugao zavisi od veličine ogledala, a prikazano je i rastojanje od kolektora na koje se postavlja.

***Ključne reči:*** *sunčevo zračenje, solarni kolektor, reflektori, ugao*

Datum prijema rukopisa: 07.11.2011.

*Paper submitted:*

Datum prijema rukopisa sa ispravkama:

*Paper revised:*

Datum prihvatanja rada: 16.11.2011.

*Paper accepted:*